

W-band High Gain Lens Horn Antenna

75 to 110 GHz, WR10, 30 dBi Gain

DESCRIPTION

Anteral's High Gain Lens Horn Antennas are composed by a rectangular waveguide feeder with high quality standard flange that illuminates a **plano-convex** Teflon (PTFE) lens in order to apply phase correction and achieve superior performance with minimum size. The lenses are designed with optimized hyperbolic profile to reduce the aberration to the minimum. The whole system is encapsulated inside an aluminum cylinder that gives high robustness and it counts with a flat side to be the antenna able to stand in a flat surface.

The LHA-HG-WR10 model operates at the W-band between 75 and 110 GHz with 36.7 dBi nominal mid-band gain and a typical VSWR of 1.5.

APPLICATIONS

High Gain Lens Horn Antennas are especially useful when high gain is required with the minimum size. Therefore, these antennas are widely used in radar applications, communication and meteorological systems among others.

Anteral also offers their **Lens Horn Antennas** that exhibit also high gain (>30 dBi) with minimum size at frequencies from 8 to 170 GHz.

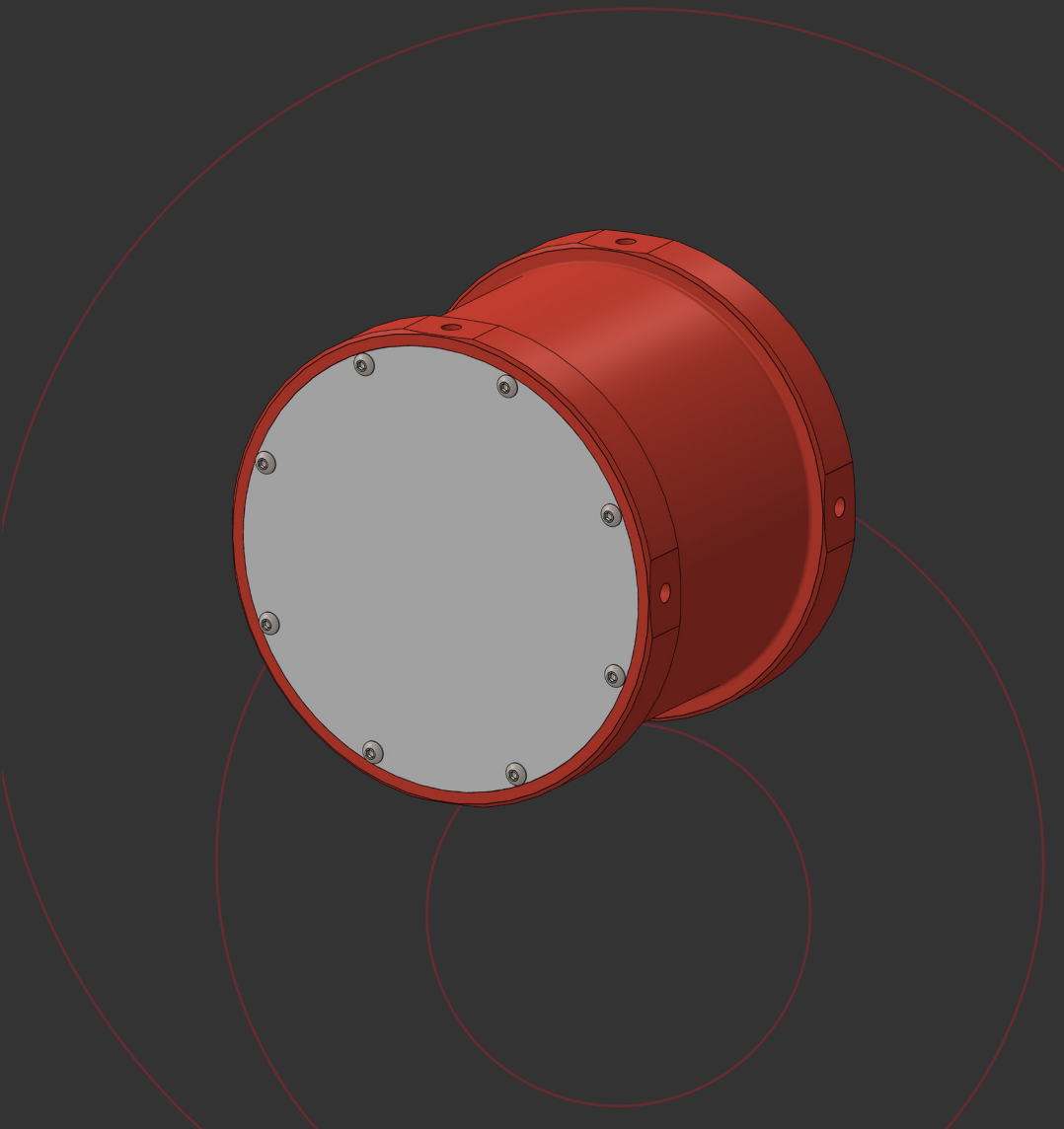

ELECTRICAL SPECIFICATIONS

Parameter	Typical value
Frequency	75 - 110 GHz
Directivity	36.7 dBi
3 dB Beamwidth, E-plane	2.6 deg
3 dB Beamwidth, H-plane	2.5 deg
Sidelobe, E-plane	-24.9 deg
Sidelobe, H-plane	-26.9 dB
S11	-14 dB

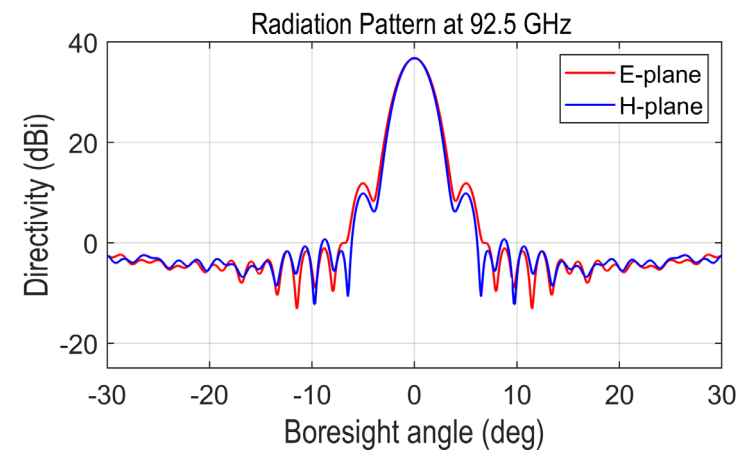
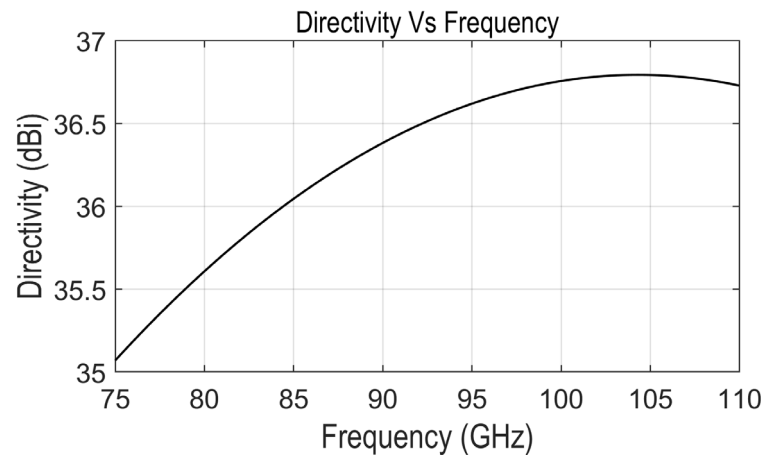

MECHANICAL SPECIFICATIONS

Parameter	Description
Antenna Port	WR-10
Flange	UG-387/U
Total length	107 mm
Total diameter	122 mm
Total weight	940 g
Horn Material	Aluminum
External Color	Ruby Red

MECHANICAL OUTLINE

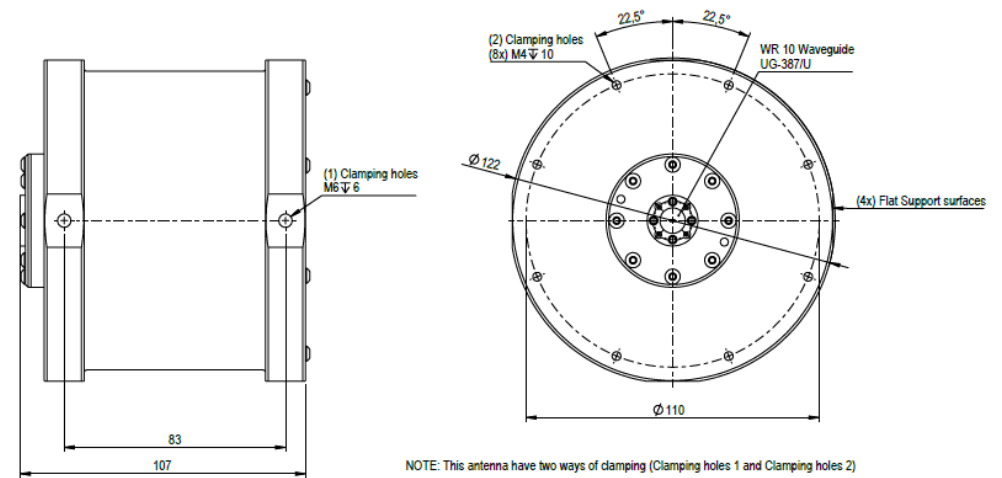

Additional notes

Directivity and radiation pattern data are simulated. Actual values have been checked experimentally but they could vary slightly. The return loss performance of all items is checked before delivery to fulfill specifications.

Last version: 06/06/2022.

