

D-Band Lens Horn Antenna

110 to 170 GHz, WR06, 30 dBi Gain

DESCRIPTION

Anteral's Lens Horn Antennas are conical horn antennas with a **plano-convex** Teflon (PTFE) lens added in the aperture, in order to apply phase correction and achieve high gain, low VSWR and low side-lobes, with minimum size.

The LHA-30-WR06 model operates at the D-band between 110 and 170 GHz with 30 dBi nominal mid-band gain and a typical VSWR of 1.2.

APPLICATIONS

Lens Horn Antennas are especially useful when high gain is required with the minimum size. Therefore, these antennas are widely used in radar applications, communication links and meteorological systems among others.

Anteral also offers their **Focusing Lens Horn Antennas** with double-convex lenses to exhibit very well define focusing beams with short focal distances which makes them optimal for testing and material characterization.

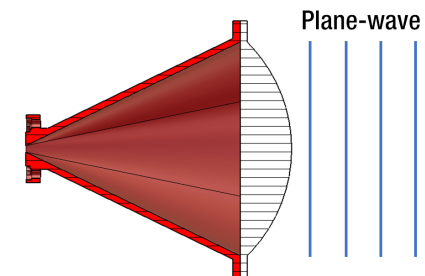

ELECTRICAL SPECIFICATIONS

Parameter	Minimum	Typical	Maximum
Frequency	110 GHz	140 GHz	170 GHz
Gain	28.2 dBi	30.2 dBi	31.7 dBi
3 dB Beamwidth, E-plane		4.9 deg	
3 dB Beamwidth, H-plane		5.4 deg	
Sidelobe, E-plane		-12 dB	-11 dB
Sidelobe, H-plane		-24 dB	-20 dB
S11		-20 dB	-15 dB

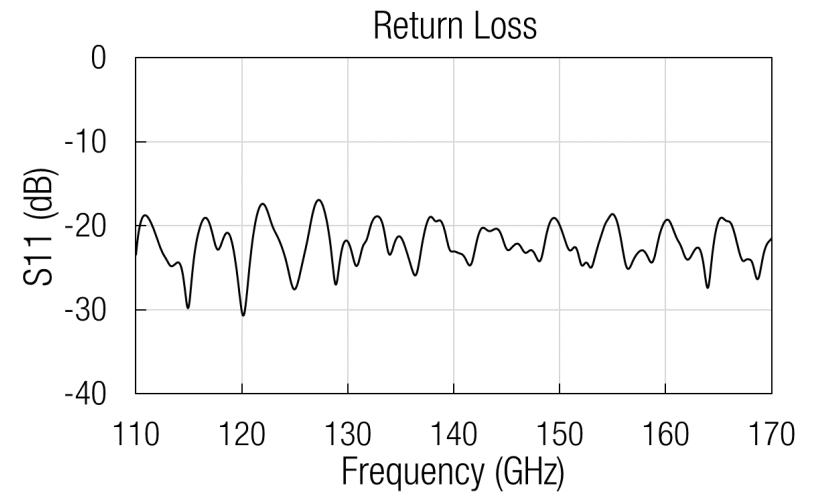
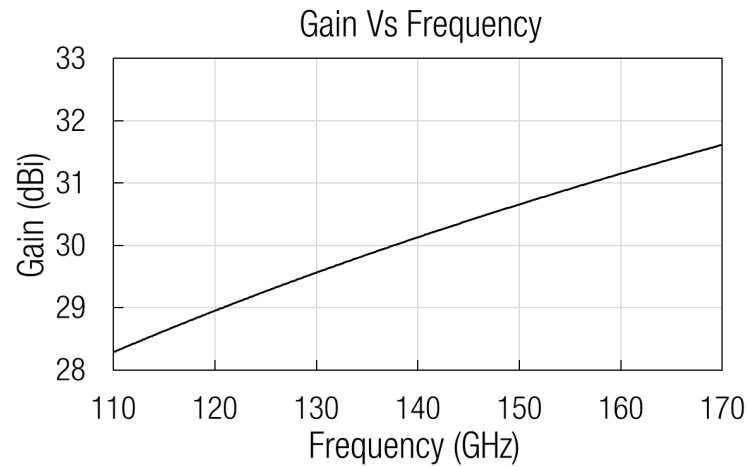
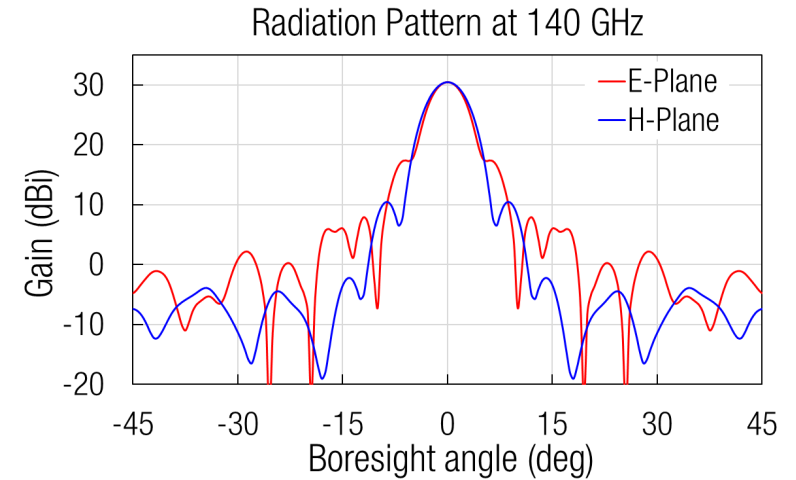

MECHANICAL SPECIFICATIONS

Parameter	Description
Antenna Port	WR-6.5 (1.6510 mm x 0.8255 mm)
Flange	UG-387/U
Total length	33.40 mm
Total diameter	37 mm
Total weight	20 g
Horn Material	Aluminum
Lens Material	PTFE
External Color	Ruby Red

MECHANICAL OUTLINE

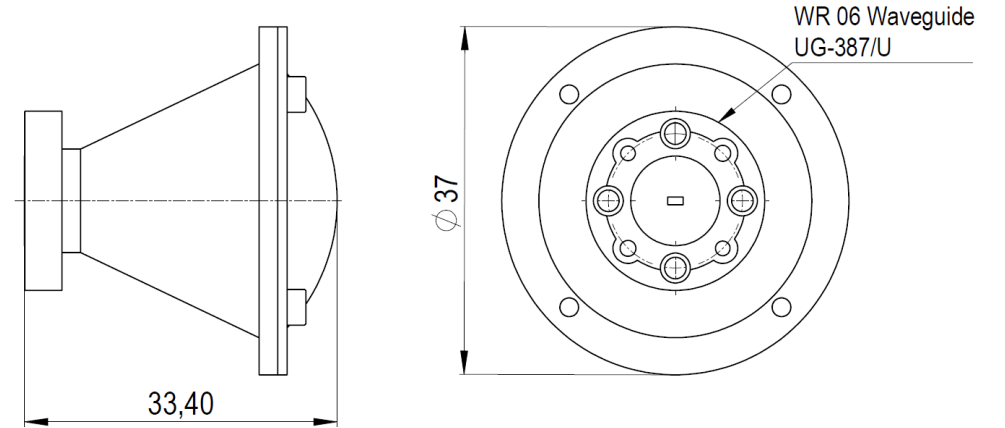

Additional notes

Gain, radiation pattern and return loss data are simulated. Actual values could vary slightly.

The return loss performance of all items is checked before delivery.