

F-Band Lens Horn Antenna

90 to 140 GHz, WR08, 30 dBi Gain

DESCRIPTION

Anteral's Lens Horn Antennas are conical horn antennas with a **plano-convex** Teflon (PTFE) lens added in the aperture, in order to apply phase correction and achieve high gain, low VSWR and low side-lobes, with minimum size.

The LHA-30-WR08 model operates at the F-band between 90 and 140 GHz with 30 dBi nominal mid-band gain and a typical VSWR of 1.25.

APPLICATIONS

Lens Horn Antennas are especially useful when high gain is required with the minimum size. Therefore, these antennas are widely used in radar applications, communication links and meteorological systems among others.

Anteral also offers their **Focusing Lens Horn Antennas** with double-convex lenses to exhibit very well define focusing beams with short focal distances which makes them optimal for testing and material characterization.

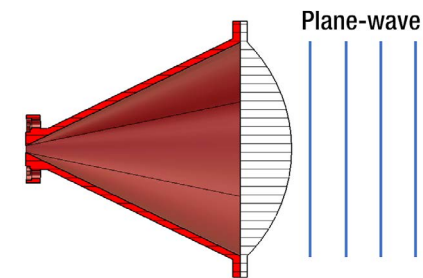

ELECTRICAL SPECIFICATIONS

| Parameter | Typical value |
|-------------------------|---------------|
| Frequency | 90 - 140 GHz |
| Gain | 30.3 dBi |
| 3 dB Beamwidth, E-plane | 5.0 deg |
| 3 dB Beamwidth, H-plane | 5.5 deg |
| Sidelobe, E-plane | -12 dB |
| Sidelobe, H-plane | -24 dB |
| S11 | -18 dB |

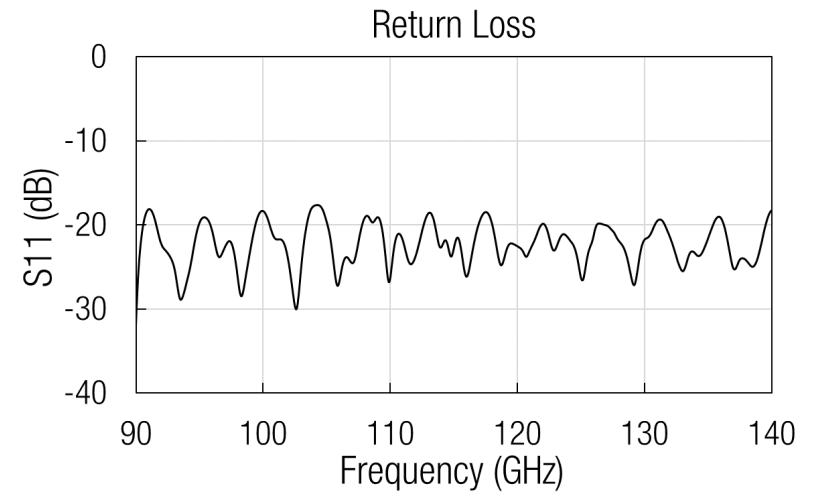
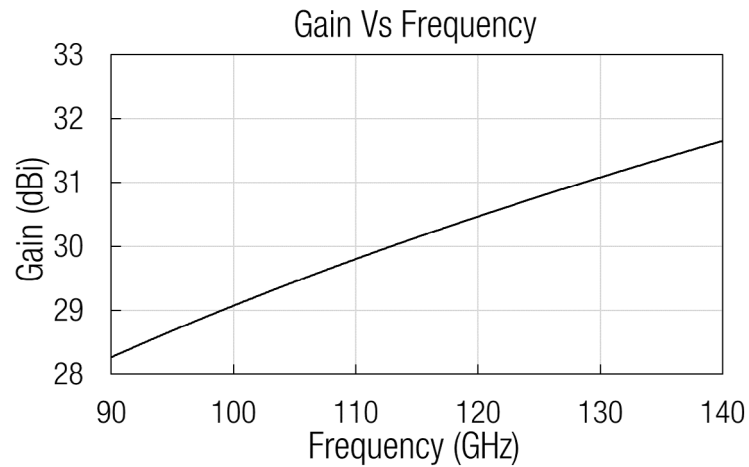
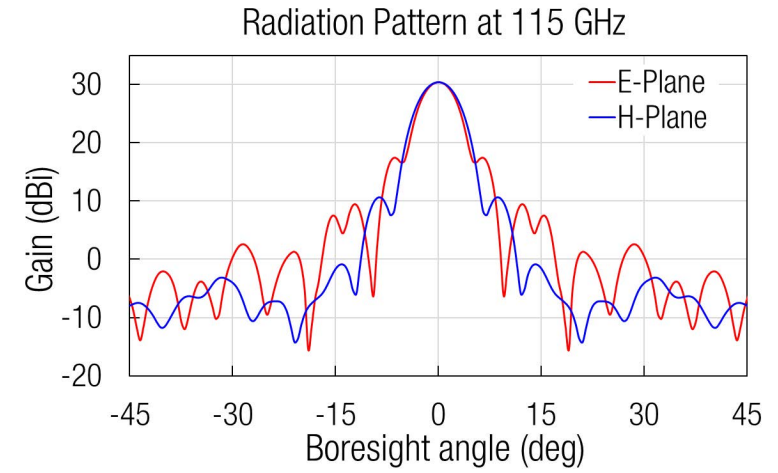

MECHANICAL SPECIFICATIONS

| Parameter | Description |
|----------------|------------------------------|
| Antenna Port | WR-8.0 (2.032 mm x 1.016 mm) |
| Flange | UG-387/U |
| Total length | 40.7 mm |
| Total diameter | 43 mm |
| Total weight | 30 g |
| Horn Material | Aluminum |
| Lens Material | PTFE |
| External Color | Ruby Red |

MECHANICAL OUTLINE

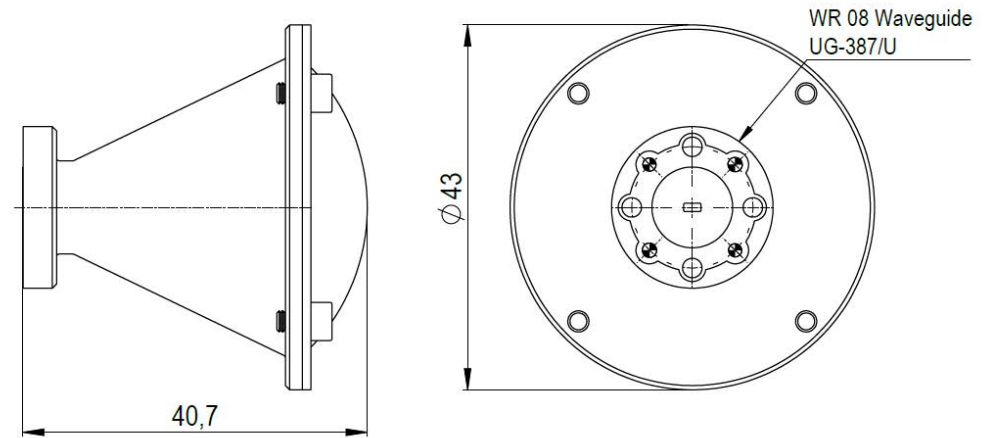

Additional notes

Gain, radiation pattern and return loss data are simulated. Actual values could vary slightly.
The return loss performance of all items is checked before delivery.
Last version: 18/01/2023

