

# W-Band Lens Horn Antenna

75 to 110 GHz, WR10, 30 dBi Gain

## DESCRIPTION

Anteral's Lens Horn Antennas are conical horn antennas with a **plano-convex** Teflon (PTFE) lens added in the aperture, in order to apply phase correction and achieve high gain, low VSWR and low side-lobes, with minimum size.

The LHA-30-WR10 model operates at the W-band between 75 and 110 GHz with 30 dBi nominal mid-band gain and a typical VSWR of 1.2.

## APPLICATIONS

Lens Horn Antennas are especially useful when high gain is required with the minimum size. Therefore, these antennas are widely used in radar applications, communication links and meteorological systems among others.

Anteral also offers their **Focusing Lens Horn Antennas** with double-convex lenses to exhibit very well define focusing beams with short focal distances which makes them optimal for testing and material characterization.

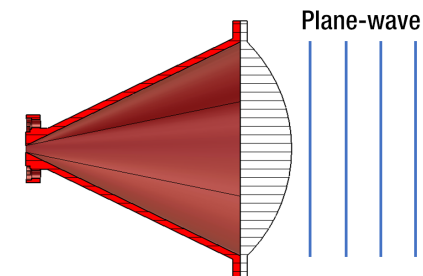

### ELECTRICAL SPECIFICATIONS

Parameter	Minimum	Typical	Maximum
Frequency	75 GHz	92.5 GHz	110 GHz
Gain	28.5 dBi	30.1 dBi	31.4 dBi
3 dB Beamwidth, E-plane		5.1 deg	
3 dB Beamwidth, H-plane		5.1 deg	
Sidelobe, E-plane		-13 dB	-12 dB
Sidelobe, H-plane		-26 dB	-21 dB
S11		-20 dB	-15 dB

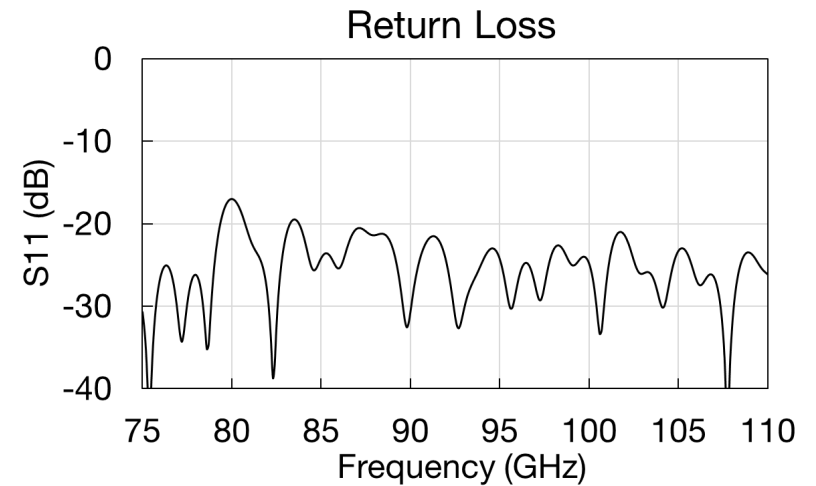
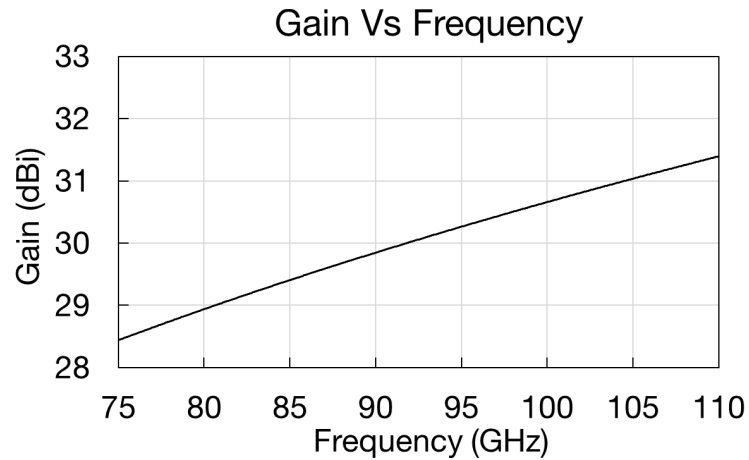
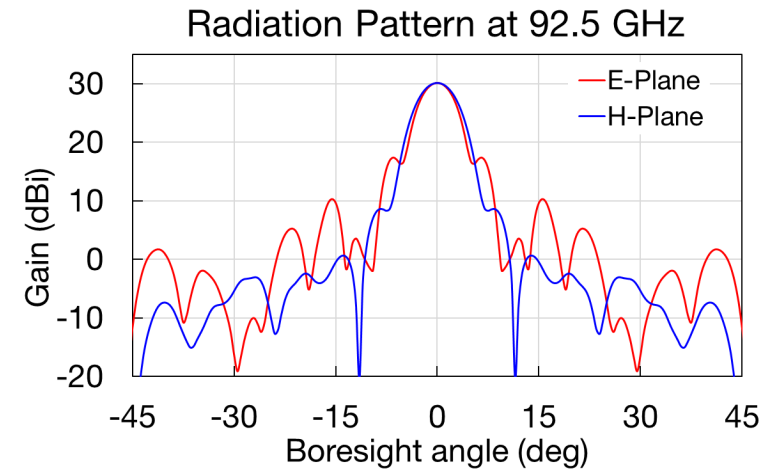

### MECHANICAL SPECIFICATIONS

Parameter	Description
Antenna Port	WR-10 (2.54 mm x 1.27 mm)
Flange	UG-387/U
Total length	51.3 mm
Total diameter	53 mm
Total weight	50 g
Horn Material	Aluminum
Lens Material	PTFE
External Color	Ruby Red

### MECHANICAL OUTLINE

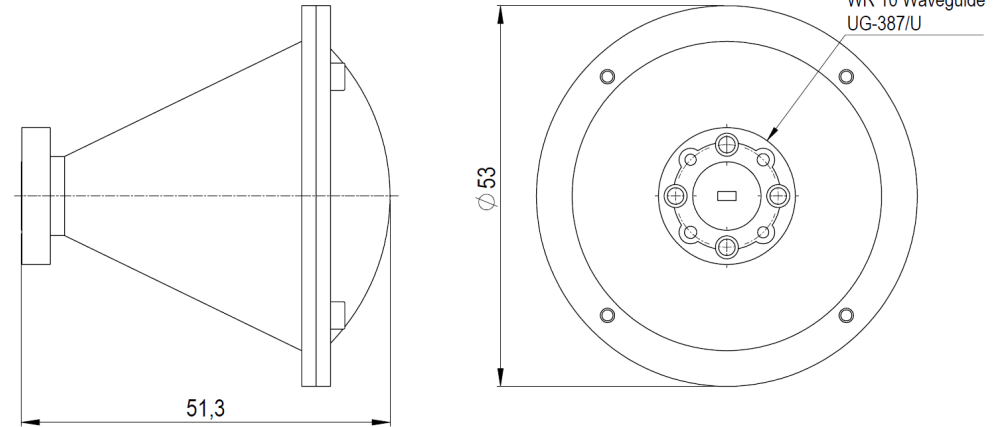

### Additional notes

Gain and radiation pattern data are simulated. Actual values have been checked experimentally but they could vary slightly.

Return loss data are measured from a sample.

The return loss performance of all items is checked before delivery.