

U-Band Lens Horn Antenna

40 to 60 GHz, WR19, 30 dBi Gain

DESCRIPTION

Anteral's Lens Horn Antennas are conical horn antennas with a **plano-convex** Teflon (PTFE) lens added in the aperture, in order to apply phase correction and achieve high gain, low VSWR and low side-lobes, with minimum size.

The LHA-30-WR19 model operates at the U-band between 40 and 60 GHz with 30 dBi nominal mid-band gain and a typical VSWR of 1.2.

APPLICATIONS

Lens Horn Antennas are especially useful when high gain is required with the minimum size. Therefore, these antennas are widely used in radar applications, communication links and meteorological systems among others.

Anteral also offers their **Focusing Lens Horn Antennas** with double-convex lenses to exhibit very well define focusing beams with short focal distances which makes them optimal for testing and material characterization.

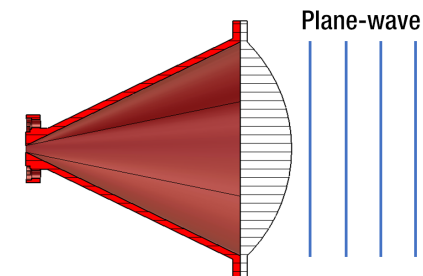

ELECTRICAL SPECIFICATIONS

Parameter	Minimum	Typical	Maximum
Frequency	40 GHz	50 GHz	60 GHz
Gain	28.6 dBi	30.5 dBi	32.1 dBi
3 dB Beamwidth, E-plane		4.6 deg	
3 dB Beamwidth, H-plane		5.9 deg	
Sidelobe, E-plane		-14 dB	-14 dB
Sidelobe, H-plane		-28 dB	-25 dB
S11		-20 dB	-15 dB

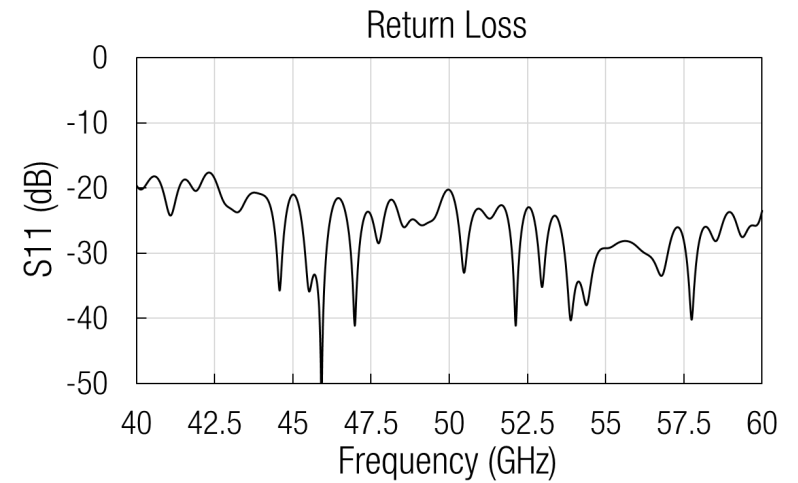
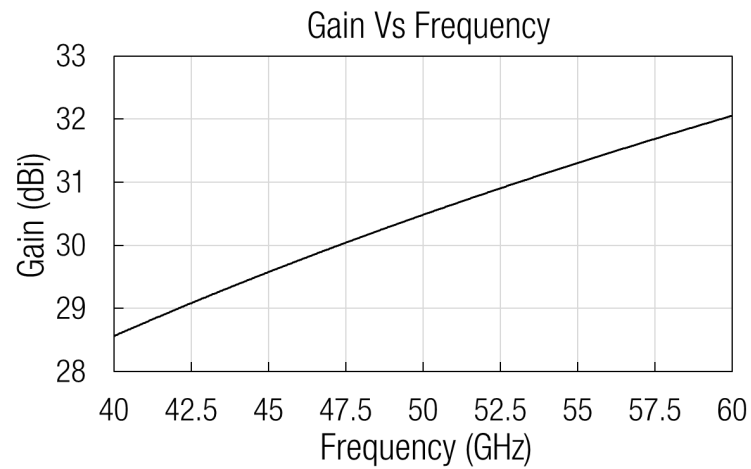
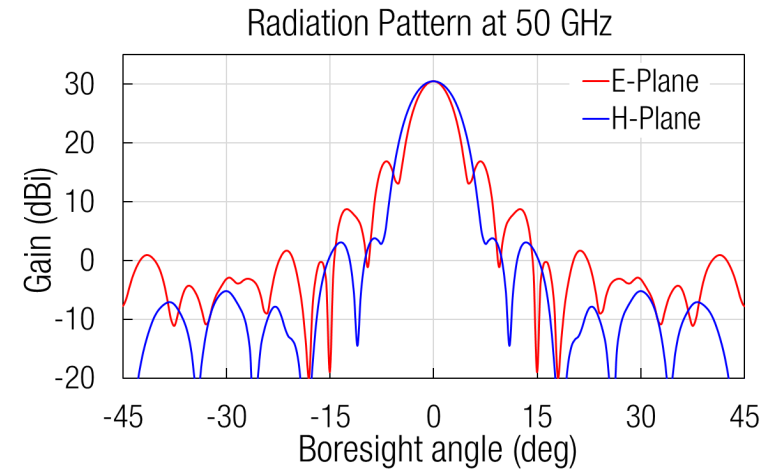

MECHANICAL SPECIFICATIONS

Parameter	Description
Antenna Port*	WR-19 (4.775 mm x 2.388 mm)
Flange	UG-383/U
Total length	104.3 mm
Total diameter	93 mm
Total weight	260 g
Horn Material	Aluminum
Lens Material	PTFE
External Color	Ruby Red

*The antenna includes a rectangular to circular waveguide transition (WR-19 to WC-430)

MECHANICAL OUTLINE

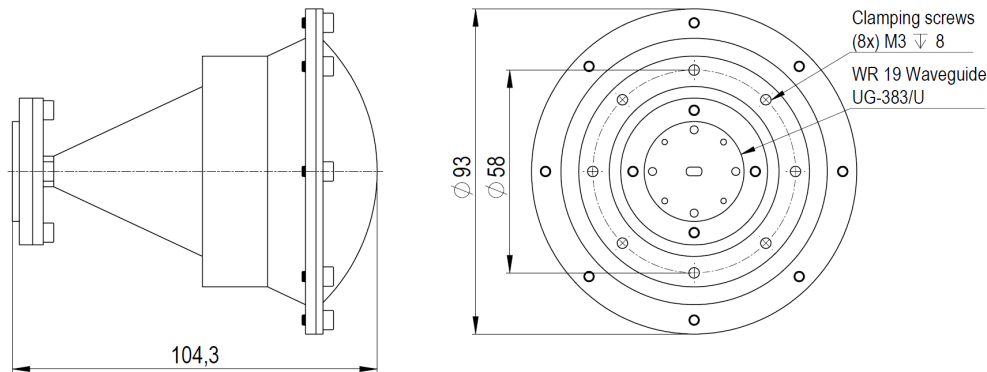

CLAMPING STRUCTURE

Anteral's Lens Horn Antennas are drilled with some threads for clamping purpose. See the mechanical outline. Anteral also offers clamping structure for the LHA-30-WR19 with the following specifications.

Model	Material	Weight (g)
LHA-30-WR19-CLAMP	Aluminum	150

*The base is drilled with 2 through holes but any custom holes can be added.

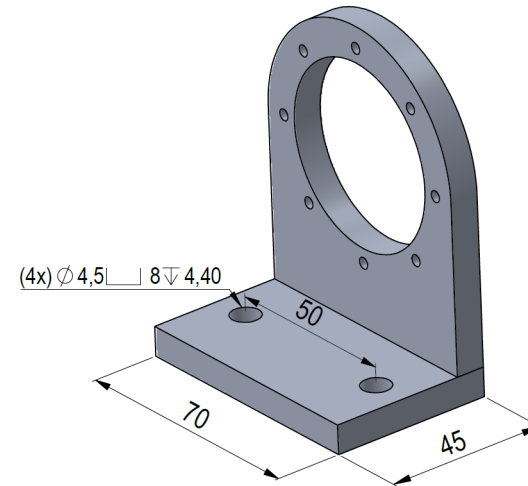

Additional notes

Gain and radiation pattern data are simulated. Actual values have been checked experimentally but they could vary slightly.

Return loss data are measured from a sample.

The return loss performance of all items is checked before delivery.