

V-Band Near Field Probe

50 to 75 GHz, WR15

DESCRIPTION

The NFP-40-WR15 is a high-performance open-ended waveguide probe that operates at the V-band between 50 and 75 GHz. It is manufactured from a single aluminium rod by high accurate manufacturing processes. The opening is sharp to reduce/minimize reflections.

All NFPs can include adequate absorber material to reduce backscattering reflections from flanges.

APPLICATIONS

This type of horns is especially suitable for laboratory test measurements, electromagnetic measurements and gain calibration. Moreover, custom bands and gain values can be requested.

Anteral also offers their **CATR** (Compact Antennas Test Range) for measuring large antennas at significant short ranges in antenna test facilities.

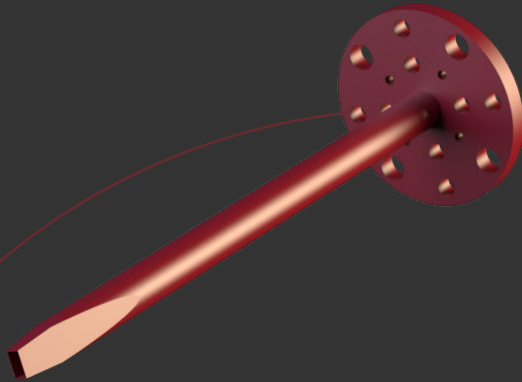

ELECTRICAL SPECIFICATIONS

Parameter	Minimum	Typical	Maximum
Frequency	50 GHz	62.5 GHz	75 GHz
Gain		7.5 dBi	
S11		-13 dB	

MECHANICAL SPECIFICATIONS

Parameter	Description
Antenna Port	WR-15 (3.759 mm x 1.880 mm)
Flange	UG-385/U
Total length	40 mm
Horn Material	Aluminum
External Color	Ruby Red

MECHANICAL OUTLINE

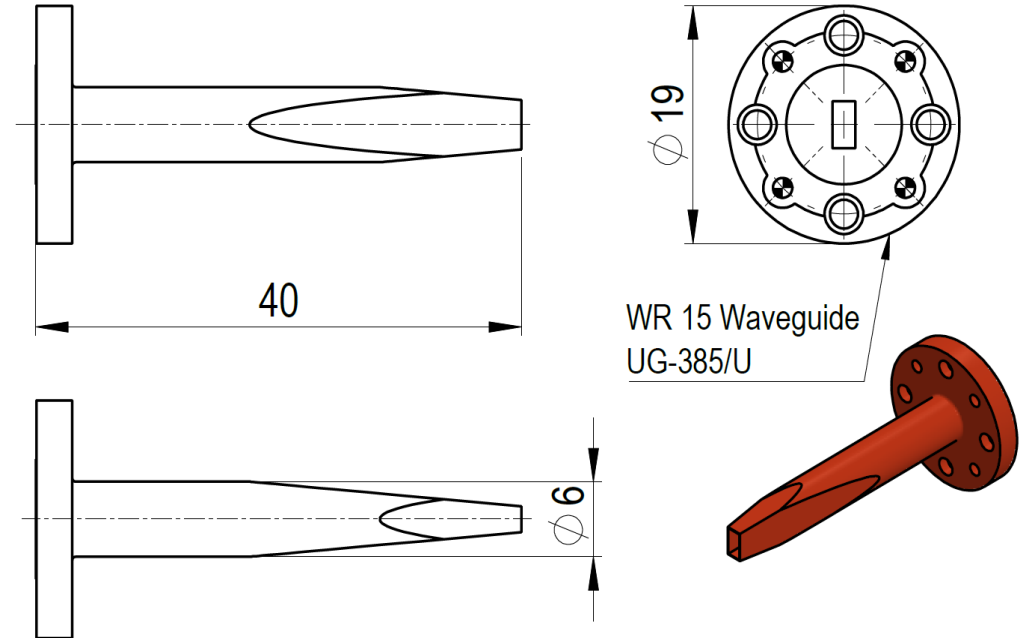

Additional notes

The return loss performance of all items is checked before delivery.